

Validation of the FLUENT CFD Computer Program by Thermal Testing of a Full Scale Double-Walled Prototype Canister for Storing Chernobyl Spent Fuel

Indresh Rampall, Ph.D., Kalyan K. Niyogi, Ph.D., Debu Mitra-Majumdar, Ph.D.

**Holtec International
555 Lincoln Drive West,
Marlton, NJ 08053**

Abstract

The spent nuclear fuel from the Chernobyl nuclear plant is designed to be stored in Double Walled Canisters (DWC) at the ISF-2 Interim Storage Facility. To provide a high degree of confidence in the results predicted by the FLUENT CFD computer code for safety evaluation of fuel storage at the ISF-2 facility a full scale prototype DWC was manufactured and tested for its thermal performance at the Holtec Manufacturing Division in Turtle Creek, PA. The DWC was instrumented and fuel heat simulated by inserting electrically heated rods in the fuel tubes under two extreme heat distribution scenarios: (i) Peripherally heated test wherein the heat is applied to the outermost storage cells; (ii) Core heated test wherein the heat is applied to the innermost storage cells. The heater tubes, storage cells, DWC shell and lid were instrumented to measure and record temperatures during the testing. To validate the FLUENT CFD code the thermal tests were simulated on FLUENT by constructing geometrically accurate 3D model of the DWC with all internals significant to mimic the thermal-hydraulic state in the DWC. These included heated rods, fuel tubes, support plates and the DWC shell. The test measurements and FLUENT results were compared and the predictability of the FLUENT CFD code for safety evaluation of fuel storage in double-walled canisters confirmed.

1. INTRODUCTION

The ISF-2 Interim Storage Facility is designed to store Chernobyl's Spent Nuclear Fuel (SNF) in the dry state in Double Wall Canisters (DWC). The DWC is a stainless steel canister engineered with two independent welded barriers (two shells, two base plates and two lids) to the release of radioactive material. Fuel is stored in an array of METAMIC fuel tubes supported by a disk-and-spacer assembly. The heat generated by the SNF is dissipated through the fuel tubes and support structures and externally to the environment. To evaluate the safety of the DWC and stored fuel the Computational Fluid Dynamics (CFD) code FLUENT is deployed for all thermally challenging scenarios. Although the FLUENT CFD code is a robust program relied upon by cask designers in the United States and elsewhere for licensing of storage and transport casks, its use is a novel first step for the Ukrainian Regulator SNRCU¹ and ChNPP (Chernobyl Nuclear Power Plant). Furthermore the fuel basket design consisting of an array of fuel tubes supported in a disk-and-spacer cage departs from the traditional integrally welded baskets. To provide a high level of assurance to the Ukrainian Regulator and the Chernobyl Plant Operator a full scale FLUENT validation test is designed as described below.

1. One full scale prototype DWC is designed and manufactured under the Holtec's quality assurance program for nuclear grade equipment.
2. The prototype DWC is powered by instrumented electric heater rods inserted in fuel tubes. The heater rods power bounds Chernobyl fuel assemblies decay power by conservative margin (See Table 1). During the test all critical temperatures are recorded.
3. The thermal test is modeled by deploying the FLUENT CFD code and the DWC temperature field is computed.

¹ Acronym for The State Nuclear Regulation Committee of Ukraine.

4. The suitability of FLUENT is evaluated for reliable and conservative prediction of critical DWC temperatures.

Table 1: Thermal Test Heat Input

	Thermal Test	DWC loaded with Chernobyl fuel
Max. Storage Cell	1 kW	79 W
DWC	12 kW	10 kW

2. TEST APPARATUS AND ITS INSTRUMENTATION

2.1 Description of Test Apparatus

In accordance with the FLUENT validation test plan articulated in Section 1 a full scale instrumented prototype DWC is constructed and thermally tested at the Holtec Manufacturing Division located in Turtle Creek, PA. The principal DWC characteristics are provided in Table 2. A cutaway view of the DWC with the internals is shown in Figure 1. The prototype DWC is tested under a thermally bounding scenario wherein the DWC is loaded with fuel in air at the ISF-2 hot cell equipped fuel processing building with the lid closed. Fuel heat was simulated by inserting twelve electrical heater rods in storage cells under two extreme heat distribution scenarios:

Case 1: Peripherally heated DWC

Case 2: Core heated DWC

The heater layout under the two scenarios is shown in Figures 2 and 3. A typical heater assembly is shown in Figure 4. The heater tubes are instrumented to measure the heater rod and fuel tube temperatures near the bottom, mid-height and top of the active length (See Figure 5). To maximize local temperatures the power input to the heated cells is substantially in excess of the maximum decay power of Chernobyl fuel (See Table 1).

Table 2: Principal DWC Characteristics

Diameter	73.81 in
Length	160.5 in
Shell thickness	0.5 inch (inner), 0.375 inch (outer)
Fuel tubes	
Number	186
Diameter	4.063 in
Length	149.76 in
Wall thickness	0.094 in
Support disks	4 (intermediate), 1 (bottom)

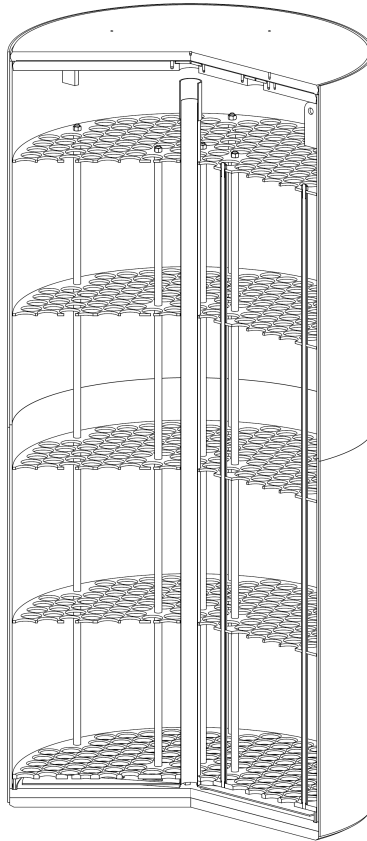

Figure 1: Cutaway View of the DWC (fuel tubes omitted for clarity)

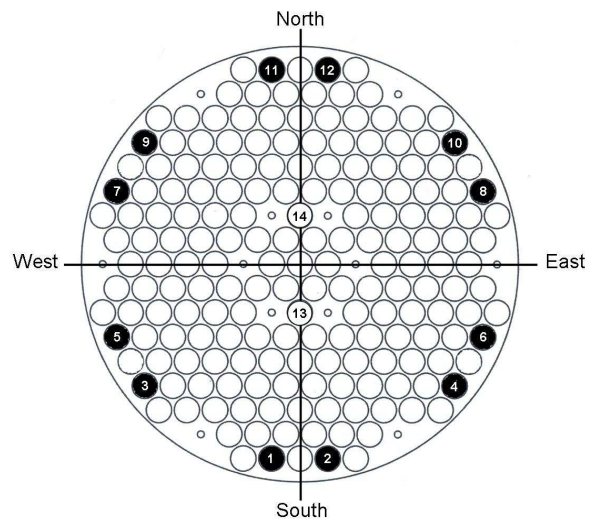

Figure 2: Case 1: Peripherally Heated Test Configuration

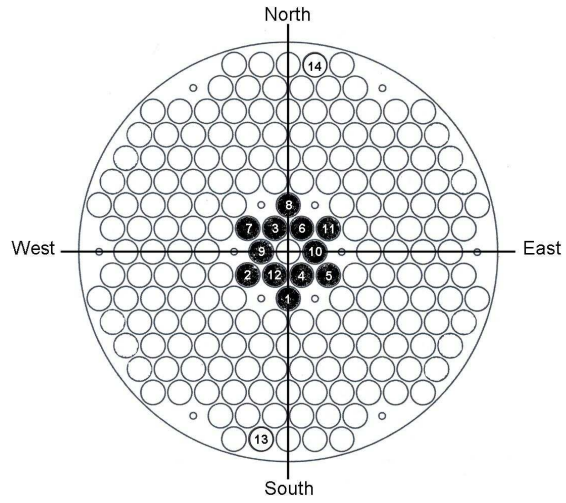

Figure 3: Case 2: Core Heated Test Configuration

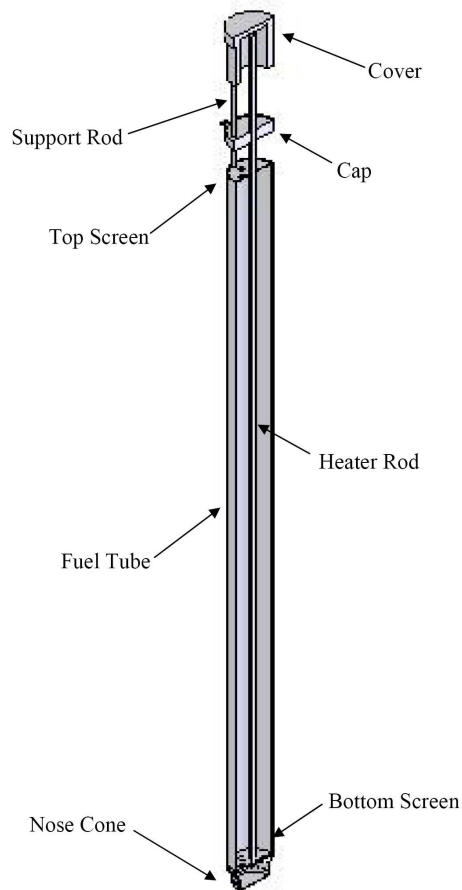

Figure 4: Fuel Tube and Heater Rod Assembly

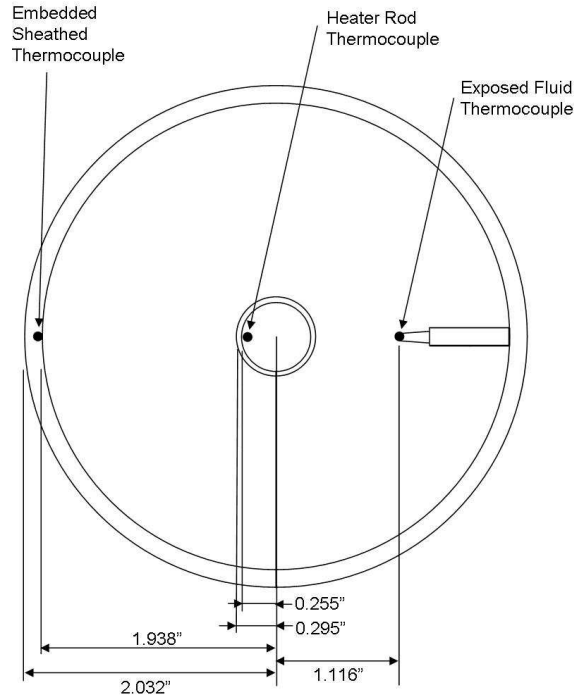

Figure 5: Heated Fuel Tube Instrumentation

2.2 Instrumentation Details

The prototype DWC is instrumented to measure the temperature field during thermal tests. Precision thermocouples are installed to measure the temperatures of Important to Safety (ITS) components within the DWC. The thermocouples are NIST calibrated to ensure temperature measurement uncertainties are within $\pm 1^\circ\text{C}$. The measurement data is recorded using LabVIEW Data Acquisition software. The instrumentation installed at the test facility is described below.

Power Measurement:

The power supply to the electrical heaters is controlled by Watlow Silicon Controlled Rectifier (SCR). The power is supplied through an array of 12 power cables wired in parallel from the Watlow junction box. The 12 kW total power output is controlled by the SCR. The output power is shared equally by the 12 parallel-wired heaters wired by virtue of their identical design and construction. The output power reading from the SCR is monitored and recorded.

Tube Instrumentation:

As shown in Figure 3.4, all 12 heated tubes have thermocouples installed to measure the heater rod, tube and fluid temperatures at three elevations. At each elevation there is a sheathed thermocouple embedded at the inside of the tube wall, a fluid thermocouple located half-way between the inside of the tube wall and the outside of the heater rod, and a thermocouple located on the inside surface of the cladding of the heater rod (See Figure 5). The three elevations, positioned within the active length of the heater rods, are at 21 in, 81in, and 141 in from the bottom of the DWC. The heated length starts 9 in from the bottom of the DWC and ends at 153 in. Two unheated tubes instrumented with the fluid and tube wall thermocouples are included in the test (tubes 13 and 14 shown in Figures 2 and 3).

Cask Instrumentation – Outer Shell:

To measure the temperature of the outer shell of the DWC sheathed thermocouples are located at 3 elevations coincident with the heated tube thermocouple elevations in four directions designated “North”, “South”, “East”, “West” shown in Figures 2 and 3.

Cask Instrumentation – Inner Wall:

Four sheathed thermocouples embedded in the inner wall of the storage cask outer shell at each of the four designated “directions” (North, South, East, and West) at 147 in elevation from the DWC bottom.

Test Lid Instrumentation:

The DWC is equipped with a test lid placed on the DWC top having openings for heater rods and thermocouples access. Five thermocouples are located on the top of the test lid. The thermocouples are located midway between the center and perimeter of the lid in each of the four orientations (North, South, East, West), with an additional thermocouple located at the lid center.

Ambient Air Instrumentation:

Five fluid thermocouples are installed to measure the ambient air temperature. Four are distributed over the DWC height a short distance from the cask perimeter. One is located approximately 3 ft above the top of the lid center.

Data Acquisition System:

The Data Acquisition System (DAS) hardware supplied by National Instruments utilizes a USB control module to create a complete plug-and-play system. The components consist of a slot chassis to house the modules, a USB control module that communicates with the computer, five 32-channel input modules to produce a 160-channel system, five corresponding thermocouple connectors, and the required cabling to connect the thermocouple connector accessories to the input modules. The DAS is connected to the DWC test facility as shown schematically in Figure 6.

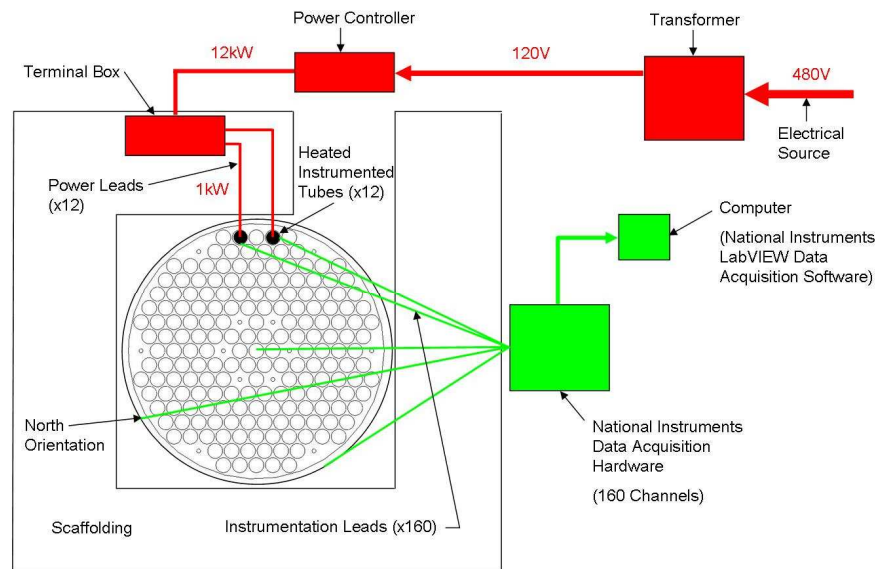

Figure 6: Test Facility Schematic

3. DWC THERMAL MODEL

To demonstrate adequacy of the FLUENT CFD code the prototype DWC thermal test configuration is modeled, temperature field computed and evaluated. The principal features of the prototype DWC and the thermal model constructed for this purpose are described in the following.

3.1 Prototype DWC Physical Characteristics

The prototype DWC is engineered with a fuel basket identical in design to the Double-Wall Canister for storing the separated upper and lower bundles of RBMK fuel assemblies. The prototype DWC is tested under a bounding ISF-2 fuel loading scenario wherein the DWC is oriented vertically, the cavity is air filled and the lid is installed. A cutaway view of the DWC is shown in Figure 1. The principal design features are:

- (i) The fuel basket is engineered with 186 Metamic tubes for storing the half-length fuel assemblies.
- (ii) The cylindrical tubes are laterally supported by drilled-hole steel plates. The cylindrical tubes bottom is contoured to rest inside chamfered tubesheet holes. The tubesheet is positioned above the baseplate so that a plenum between the baseplate and the tubesheet is created.
- (iii) The tubesheet and the array of support plates are fastened to each other by six tie rods.
- (iv) The central tube required during fuel drying operations is included in the prototype DWC.
- (v) The bottom plenum baffle plate required to direct gas flow during drying operations is included in the prototype DWC.
- (vi) The tubes are capped with a removable top cover. The top cover and tube bottom are equipped with vent holes to enhance fuel cooling under fuel loaded conditions and facilitate fuel drying operations.
- (vii) The fuel basket is enclosed by a double-walled stainless steel confinement vessel.

3.2 DWC Thermal Model

The prototype DWC is essentially an array of Metamic fuel tubes laterally supported by steel disks. The fuel basket is confined inside the cylindrical cavity of the DWC. To ensure an adequate representation of the fuel basket a geometrically accurate 3D model of the array of fuel tubes is constructed using the GAMBIT pre-processor. The 3D model explicitly includes the DWC components. All physical components, including the fuel tubes, support plates, bottom tubesheet and stainless steel enclosure vessel are included in a 1/12-Symmetric thermal model (See Figure 6.1). The essential features of the model are presented below:

- The fuel tubes, support plates, bottom tubesheet, and double walled stainless steel enclosure vessel are explicitly modeled.
- The heater rods in the locations under Case 1 and Case 2 scenarios (See Figures 2 and 3) are explicitly modeled in the fuel tubes.
- The heater power is modeled as volumetric heat source in the heated length.
- Convection in the DWC spaces, which is intrinsic to the fuel basket design, is enabled in the model.
- Conduction and radiation heat transfer are enabled in the model.
- The bottom surface of the DWC is conservatively assumed to be insulated.
- Heat dissipation by radiation and natural convection to still air from the DWC shell and lid are included in the model. Convection heat transfer is modeled in accordance with Jakob & Hawkins correlation [1] for natural convection cooling from heated surfaces in the turbulent regime ($Ra > 10^9$) as given below:

$$h_c = 0.19 \Delta T^{1/3} \text{ (heated vertical surfaces)}$$

$$h_c = 0.22 \Delta T^{1/3} \text{ (heated horizontal surfaces)}$$

where, h_c is convection coefficient and ΔT is surface-to-ambient temperature differential in conventional US units.

To ensure a robust representation of the significant-to-heat transfer features of the DWC the fuel tubes, heater rods and fluid regions are fine meshed. A planar view of the FLUENT mesh is shown in Figure 7. The 3D model was generated by extruding the planar mesh in the axial direction with a large number of cells (over one hundred). An isometric view of the thermal model is shown in Figure 8. Thermo physical properties of structural steel used in the DWC (SS-304) are obtained from the ASME Code [2]. Thermo physical properties of air obtained from Rohsenow & Hartnett [3] are applied to the model. Thermo physical properties of Metamic fuel tubes characterized in a proprietary Holtec test program are applied to the thermal model. The thermal model is solved to obtain the steady state DWC temperature field under the two test configurations defined in Figure 2 (Peripheral Heating Test) and Figure 3 (Core Heating Test). The FLUENT results are presented and evaluated in Section 4.

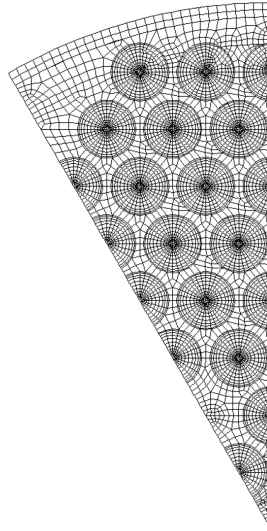

Figure 7: Planar View of 1/12-Symmetric DWC Thermal Model

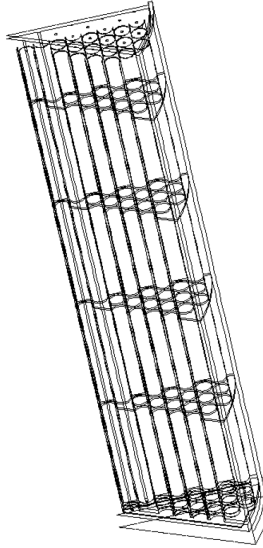

Figure 8: Isometric View of 1/12-Symmetric DWC Thermal Model

4. THERMAL TEST DATA

The prototype DWC thermal tests were conducted under the two bounding scenarios defined in Figure 2 (Peripheral Heating Test) and Figure 3 (Core Heating Test). The thermal tests were conducted at the HMD's South Shop in accordance with written test procedures. Test data was recorded electronically by the Data Acquisition System (DAS) and post processed to obtain the maximum measured temperatures of critical components (rod, fuel tube and DWC shell).

4.1 Peripheral Heating Test

The Case 1 Peripheral heating test was conducted in November 2008 with the DWC initially at room temperature. The power was turned on and ramped up from 0-12 kW over a 24 minute period. The test was terminated next day after approximately 28 hours of full power operation. Steady-state conditions were reached after approximately 25 hours of full power operation. During the tests all twelve heater rod temperatures at the three elevations, El. 21 in, El. 81 in, and El. 141 in were monitored and recorded. The test observations are as follows:

1. The heater rod and tube temperatures ramped quickly followed by monotonic approach to steady state.
2. The temperatures of the heater rod, fuel tube and DWC shell were higher at the upper elevation locations. Highest temperature was measured by the top El. 141 in thermocouples. These observations are consistent with upward flow of heated gases due to buoyancy forces on the heated fuel tubes.
3. The heater rod temperatures exhibit bounded rod-to-rod variations. The highest temperature was recorded by the Heater Rod #12 thermocouples.

For post processing and evaluation of thermal test the DAS sampling rate during approximately the last two hours of the thermal test was increased from 30 sec to 1 sec under two 15 minute steady state windows defined as SS#1 and SS#2. Time-averaged axial temperature plots of critical components during the SS#1 and SS#2 windows are plotted as follows:

Hottest Heater Rod#12: Figure 9

Hottest Fuel Tube#12: Figure 10
 Hottest North Location DWC Shell: Figure 11

The FLUENT predicted temperatures of the heater rod, fuel tube and DWC shell are plotted in these figures to facilitate evaluation of results in Section 5.

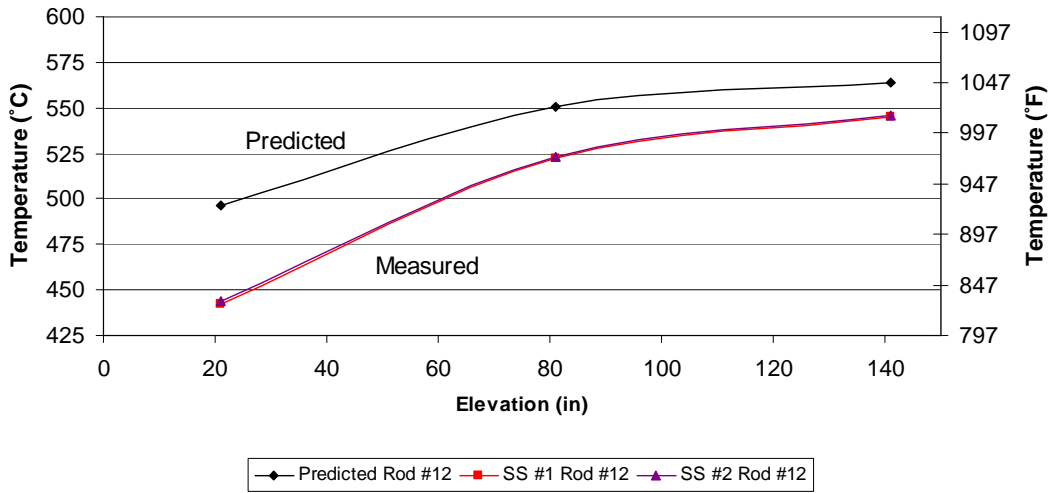

Figure 9: Case 1: Hottest **Heater Rod#12** Measured and FLUENT Computed Results

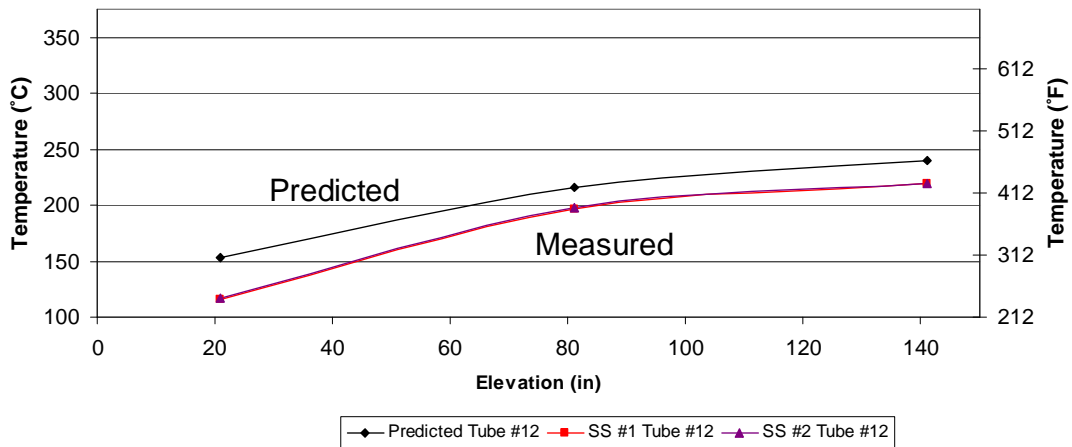

Figure 10: Case 1: Hottest **Fuel Tube#12** Measured and FLUENT Computed Results

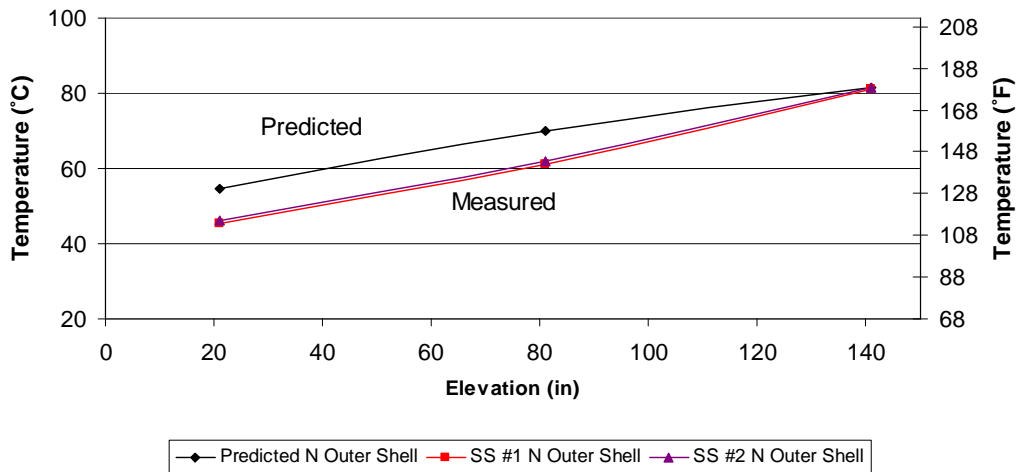

Figure 11: Case 1: Hottest North Location **DWC Shell** Measured and FLUENT Computed Results

4.2 Core Heating Test

The Case 2 Core heating thermal test was conducted in November 2008. The test was conducted at full power and terminated the next day after approximately 26 hours of operation. Steady-state was reached after approximately 25 hours of full power operation. During the tests all twelve heater rod temperatures at the three elevations, El. 21 in, El. 81in and El. 141 in were monitored. The test observations are as follows:

1. The heater rod and tube temperatures ramped quickly followed by monotonic approach to steady state.
2. The temperatures of the heater rod, tube and shell are increasing function of elevation. Highest temperature is measured by the top elevation (El. 141 in) thermocouples.
3. Highest temperatures are reached in the innermost row of rods (See Figure 3).
4. Highest temperature is recorded by the Heater Rod #3 thermocouples.

For post processing and evaluation of thermal test the DAS sampling rate during approximately the last hour of the thermal test was increased from 30 sec to 1 sec for two 15 minute steady state windows SS#1 and SS#2. Time-averaged temperature plots of critical components during the SS#1 and SS#2 windows are plotted as follows:

Hottest Heater Rod#3: Figure 12

Hottest Fuel Tube#3: Figure 13

Hottest North Location DWC Shell: Figure 14

The FLUENT predicted temperatures of the heater rod, fuel tube and DWC shell are plotted in these figures to facilitate evaluation of results in Section 5.

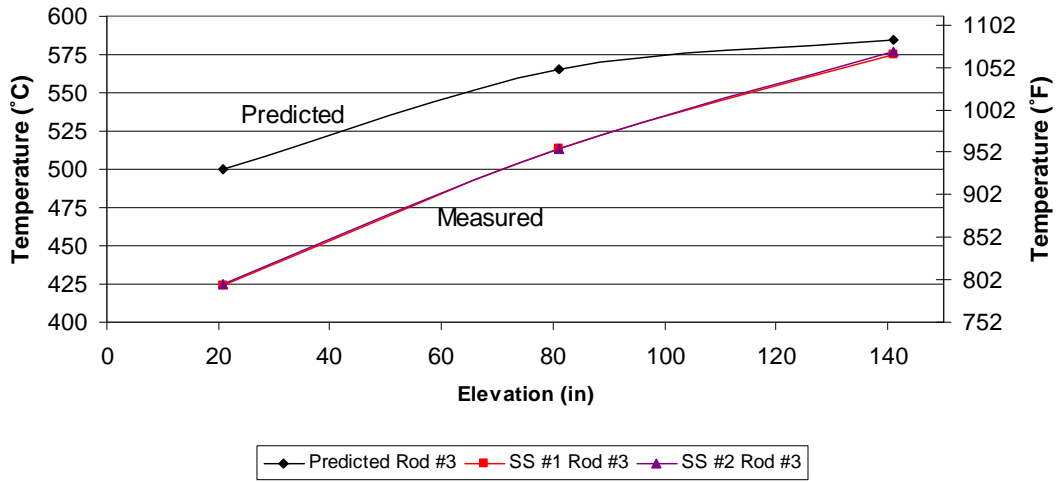

Figure 12: Case 2: Hottest **Heater Rod#3** Measured and FLUENT Computed Results

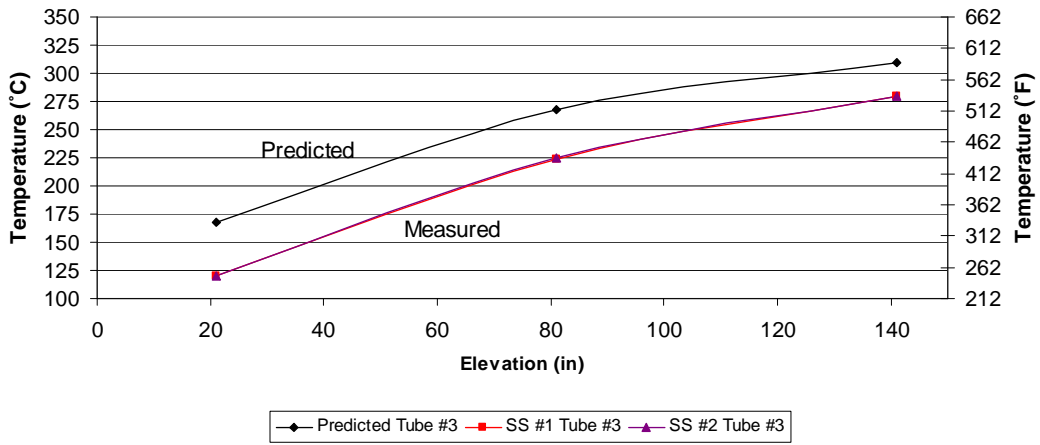

Figure 13: Case 2: Hottest **Fuel Tube#3** Measured and FLUENT Computed Results

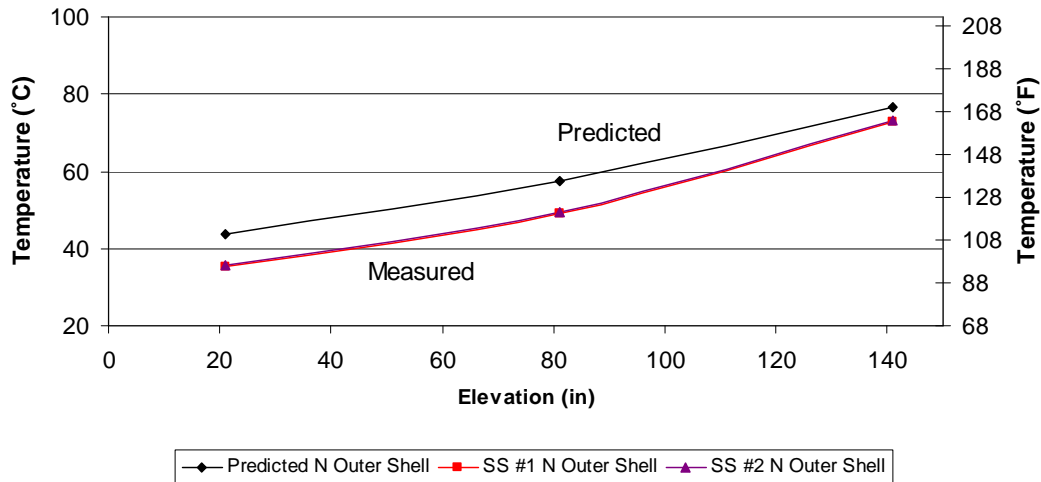

Figure 14: Case 2: Hottest North Location **DWC Shell** Measured and FLUENT Computed Results

5. CONCLUSIONS

The test measurements and FLUENT computed results plotted in Figures 9 through 14 supports the following observations:

1. The FLUENT computed heater rod temperatures track the measured temperatures of the hottest rod from above under all tested configurations (See Figure 9 and 12).
2. The FLUENT fuel tube temperatures track the measured temperatures of the hottest tube from above under all tested configurations (See Figure 10 and 13).
3. The FLUENT DWC shell temperatures track the hottest measured North location temperatures from above under all tested configurations (See Figure 11 and 14).

The following conclusions are drawn from the tests and observations above:

1. The FLUENT code yields conservative temperature predictions of critical components.
2. The FLUENT code is a suitable vehicle for performing safety evaluations of Chernobyl fuel stored in Double Wall Canisters.
3. The validation work undertaken herein provides additional assurance of the veracity of thermal calculations supporting safety evaluation of Chernobyl fuel storage at the ISF-2.

6. REFERENCES

- [1] Jakob, M. and Hawkins, G.A., *Elements of Heat Transfer*, John Wiley & Sons, New York, 1957.
- [2] Rohsenow, W.M. and Hartnett, J.P., *Handbook of Heat Transfer*, McGraw Hill Book Company, New York, (1973).
- [3] ASME Boiler and Pressure Vessel Code, Section II, Part D, (1995).

7. ACKNOWLEDGEMENTS

The Pennsylvania State University's Mechanical and Nuclear Department assistance in the instrumentation, data acquisition and operation of the DWC thermal test facility is duly acknowledged.